



**United Air Specialists, Inc.**

a CLARCOR company

## *Models SCA and SCB*



Model SCA



Model SCB

CEILING-MOUNT CARTRIDGE DUST COLLECTORS

*Clean air. It's what we do.™*

# MODELS SCA AND SCB

Industrial  
Dust Collectors for  
Ambient Air  
and Contaminants  
directly at the  
Source.



## INNOVATIVE ANSWER

Need a solution for industrial welding smoke, fumes, dust and powders, but don't have space for a large cleaning unit on the plant floor? Then check out United Air Specialists' new SCA/SCB self-contained cartridge dust collector. Designed to capture hazardous contaminants at the source or in ambient air, this ceiling-mounted system ensures clean air without giving up valuable factory floor space.

## SCA—AMBIENT AIR COLLECTION

The SCA model is the perfect choice for applications where source capture is impractical. Installed above the plant floor, this continuous cleaning ventilation system draws fumes, dust and other airborne contaminants from the workspace into the collector, and recirculates clean air back into the plant. As a result, workers are able to benefit from healthy breathing conditions as well as unrestricted movement in their workspace.

## SCB—SOURCE COLLECTION

For applications requiring dust and smoke removal right at the source, select the SCB model. This system features two lightweight, counterbalanced swing arms. Unique extension arm mounting plates are positioned for maximum and equal reach, allowing one unit to be centrally located between workstations for ultimate source capture in each area.

## APPLICATIONS

- Bulk Powders
- Drilling
- Dry Chemicals
- Carbon Black
- Cast Iron
- Grinding
- Paint Pigment
- Paper Dust
- Spices
- Welding
- Wood Dust

### *Safety Cable*

Secures "QuickSeal" Release Doors while filters are changed overhead.



Clean air. It's what we do.™

# FEATURES AND BENEFITS

## *Inlet Baffle*

Slows down air for even distribution to cartridges and improves overall cleaning.

## *External Motor/Blower*

Offers easy access for routine service and maintenance.

## *Supra-NetMax Filters*

Enable cartridge rotation and limit dust release when replacing filters.

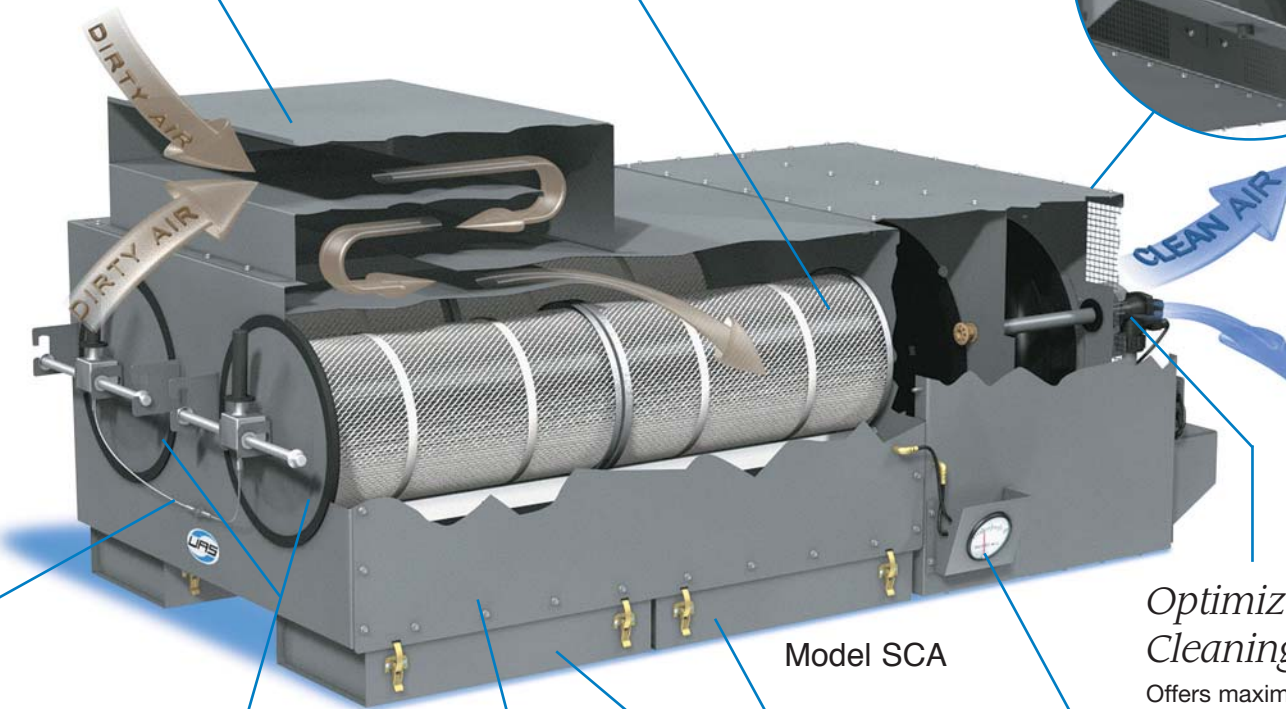
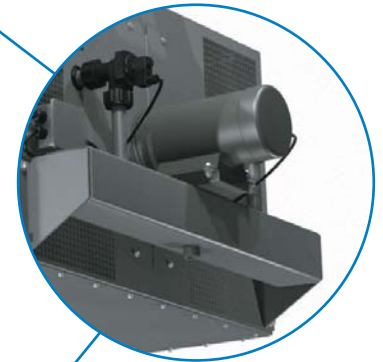

## *Optimized Cartridge Cleaning System*

Offers maximized cleaning power as a result of spring-free pulse valves and optimized nozzle.

## *"QuickSeal" Release Doors*

Provide fast filter removal and maintenance with one simple hand movement.



Model SCA

## *Powder-Coated Finish*

Prevents fading and chalking.

## *Removable Dust Drawers*

Offers large-capacity storage and easy removal of collected particles.

## *Magnahelic or Optional Photohelic Pressure Gage*

Monitors pressure and indicates when filters need to be changed.



## BETTER OVERALL CLEANING

The SCA/SCB is better than other self-contained collectors in the industry, due to its pulse cleaning technology and innovative nozzle design. Instead of simply collecting dust onto filters, the SCA/SCB captures contaminants and “pulses” them off to drawers below. A showerhead-like nozzle ensures an even distribution of air to maximize the entire length of each cartridge. The result is longer filter life, less filter changes and more clean air plant-wide.

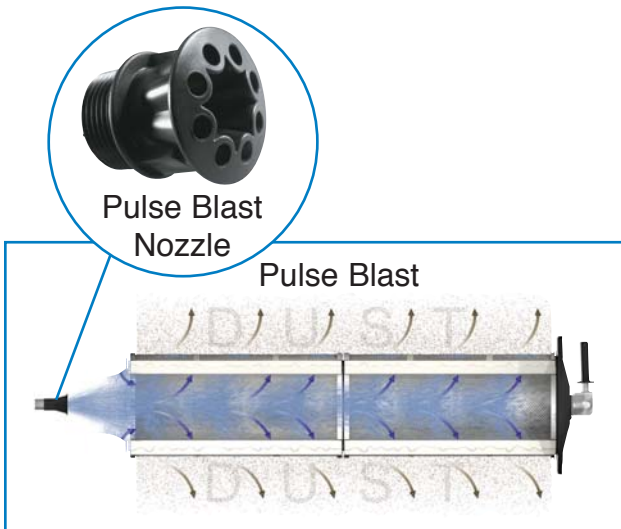

## QUIET AND EASY TO MAINTAIN

The new SCA/SCB system is quieter and easier to maintain than other dust collectors. An internal pulse cleaning system minimizes noisy air blasts and keeps sound levels below 77 dBA—under the industry standard.

Each SCA/SCB is equipped with four lightweight, removable dust drawers for easy disposal of collected material. One drawer holds .77 ft.<sup>3</sup> of dust and is simple to clean. Users just undo fasteners beneath the unit, empty the contents and attach the drawer back into place.

Another feature for simplified maintenance is the “QuickSeal” filter access door. These doors offer easy removal and replacement of cartridges as well as ensure correct and constant compression of filter seals.

## OPTIONAL LEFT OR RIGHT DISCHARGE

SCA/SCB units come standard with rear clean air discharge, but can be ordered with left- or right-hand side discharge to control the direction of airflow. And, side discharges don’t require add-on plenums—a savings in overall product cost! A UAS Representative can assist in evaluating your application requirements to determine the best direction of clean clean airflow.



Model SCA (rear view)

## SPECIFICATIONS

Model	Dimensions (HxWxL in.)	Horsepower (HP)	Voltage	Airflow (CFM)	Compressed Air Required	No. of Swing Arms	No. of Cartridges	Weight (lbs.)
SCA	39.6 x 45 x 97.8	3	230-460/3/60	2,500	.78 SCF/pulse	N/A	4 (1,020 ft. <sup>2</sup> media)	837
SCB	29.5 x 45 x 97.8	3	230-460/3/60	2,000 (1,000/arm)	.78 SCF/pulse	1 or 2	4 (1,020 ft. <sup>2</sup> media)	770 without arm

## SWING ARMS

Designed for capturing and collecting airborne particles created by industrial processes directly at the point of generation, SCB units use the highest quality and most durable swing arms in the industry. This source capture system collects nearly 100% of pollutants from the air before they enter the worker's breathing zone—a necessity in applications that pose acute respiratory hazards.

SCB source capture arms are available with standard 8" or optional 6" diameters, and choice of 7', 10' or 14' lengths. Each arm features a hood with a parabolic mouth and entrance flange. By incorporating a parabolic, or oval design, the hood alters air patterns to capture smoke, fumes and dust at a greater distance from the source than other units of its kind.



The entrance flange surrounding the hood's mouth increases the airflow velocity to pull pollutants into the system that normally escape other conventionally designed source capture systems. Additionally, each SCB arm is able to rotate 360° for optimal positioning in the operators' workspace.

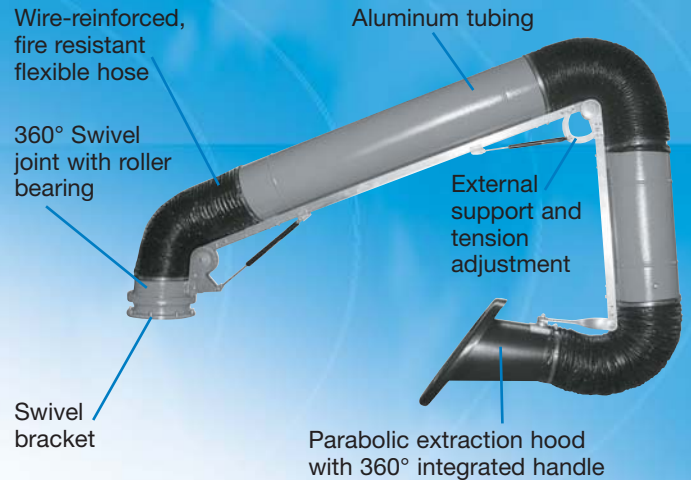

Standard hood design allows smoke bypass.



Our exclusive hood design with parabolic opening and inlet flange can collect smoke at a greater distance.

## SCA/SCB ACCESSORIES

- Left- or right-hand side discharge
- Photohelic gage
- Non-sparking fan wheel
- 200-volt option on SCB
- Fire resistant filters
- Washable media filters
- Spun bond polyester media
- Choice of 7', 10' and 14' swing arms
- 6" diameter swing arm
- Light kit for swing arm

## WHY CHOOSE UNITED AIR SPECIALISTS?

**A world-renowned reputation.** For more than 35 years, we've been the industry leader in air quality technology — a proven track record that speaks for itself.

**Commitment to quality products.** Measuring our quality against documented expectations, we practice continuous improvement methods to anticipate challenges and implement successful solutions.

**Unparalleled customer support.** As a customer-driven solutions provider, we earn credibility and establish successful relationships by exceeding expectations for professional service and attitude.

**Innovative technical leadership.** Always, we keep technology at the forefront — ensuring continuous product advancements through ongoing investments in design and manufacturing.

### UAS HEADQUARTERS – USA

4440 Creek Road  
Cincinnati, Ohio 45242  
1-800-252-4647  
www.uasinc.com

AN ISO9001 CERTIFIED COMPANY

### UAS – GERMANY

Otto-Hahn-Strasse 6  
D-65520 Bad Camberg  
Ph: +49-6434-94220  
E-mail: info@uas-inc.de

### UAS – UNITED KINGDOM

PO Box 17  
Folly Lane  
Warrington, Cheshire  
England WA5 0NP  
Ph: +44-1925-654321  
E-mail: post@clarcoruk.com

### UAS – ASIA

Flat 1, 15/F, Block 1  
Grand Pacific Views, Palatial Coast  
Siu Lam, Tuen Mun  
New Territories, Hong Kong  
Ph: +852-2814-7722  
E-mail: dlee@clarcor.com



*Clean air. It's what we do.™*